

Revealing choices in the Dutch energy system debate

From single point optimization to generating alternatives

Isai Magan - TNO
Contact: isai.magan@tno.nl

DTU PES Summer School 2026

Team: Floris van de Beek, Ni Wang,
Sebastian Hers, Isai Magan

To Make the Right Choices, We need to know the Consequences of our Choices

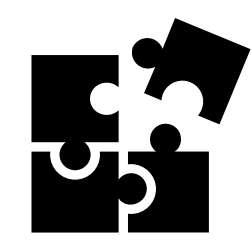

The energy is a **complex puzzle** that needs to be put together by **policy makers**. We can support them by providing an **informed basis** on how the **Dutch energy system** can be **organized** by showing the consequences of the choices in terms of **cost of energy**, **climate impact**, **land use**, **public acceptance**, **strategic dependency** on other countries and much more. Aspects that are very difficult to capture in a techno-economic model, right?

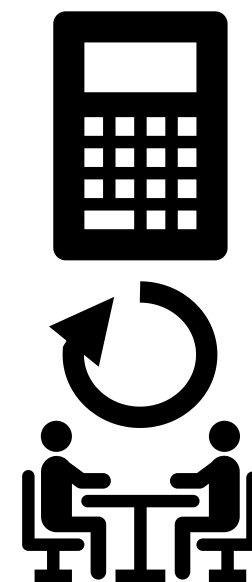

Instead, we propose to **leave** these aspects **out** of our models by arming policy makers with different configurations that all respect the same restrictions. As a demonstration, we employed energy system optimization model **Calliope** and calculated ~600 maximally different pathways that all lead to a low-cost system. The model **explores** the solution space within a limited range **around** the **global optimum**. This reveals the **must-haves** and the **real-choices**.



With these results, policy makers can trade-off aspects beyond the model scope and define **goals** for **deployment** of e.g. wind, solar, batteries, nuclear power plants and other technologies - knowing they all lead to a reliable, affordable and sustainable energy supply.

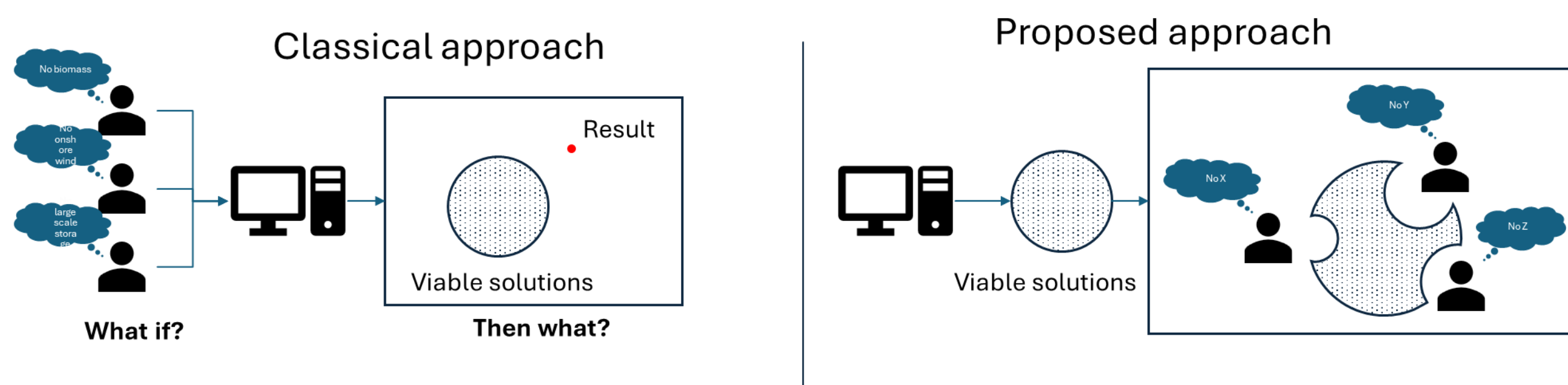

In Energy System Optimization, Local Optima are not Problems, They are Opportunities

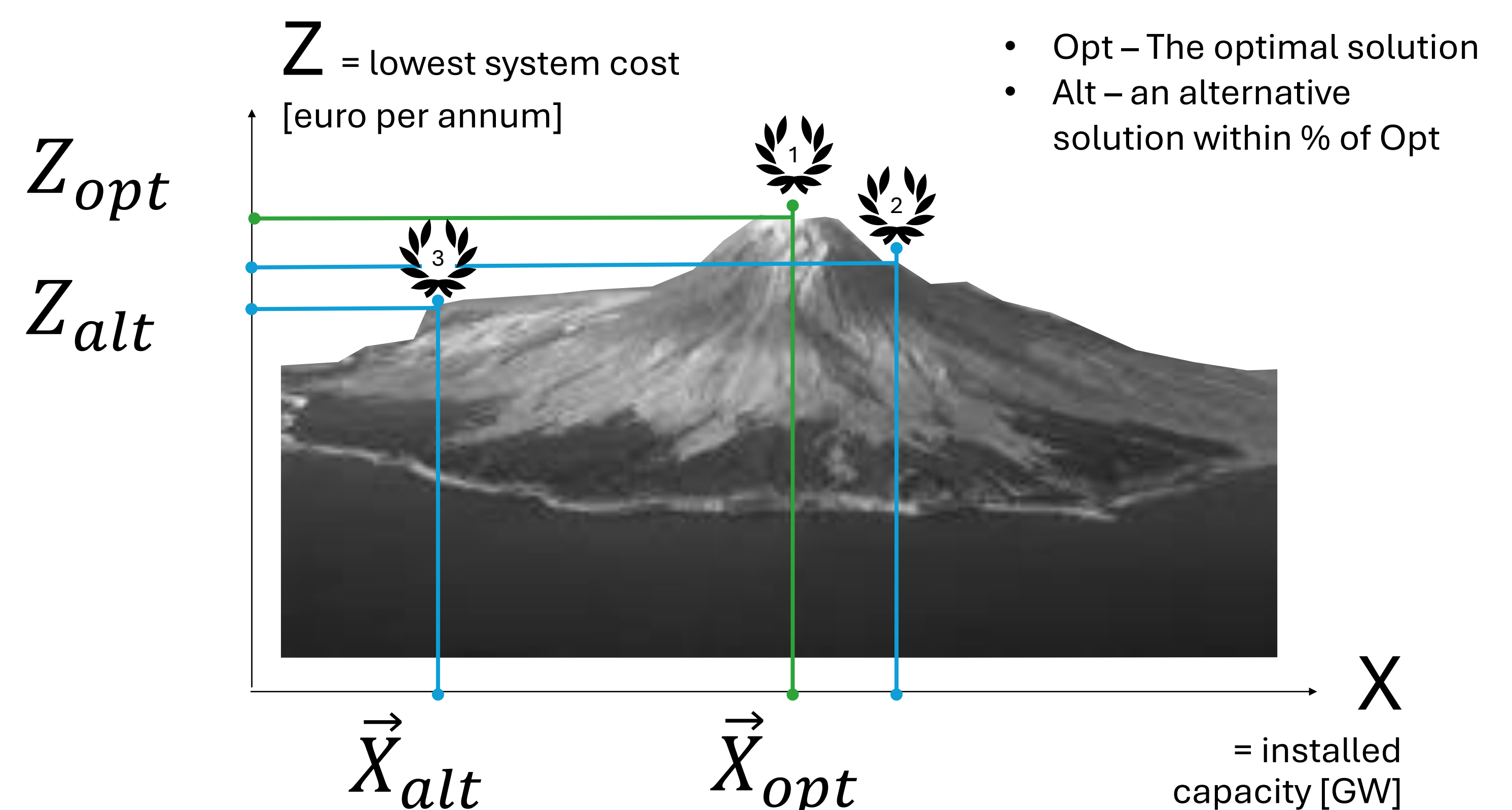

The volcano* is an analogy for the landscape of linear energy system optimization problems. Optimization algorithms are very effective in finding the volcano peak (the **global optimum**). But when we look at the volcano, the **suboptimal solution** provides a very different solution X to the exact same problem, while performing only slightly worse in total cost Z. This is very interesting information for decision makers, as it allows them to trade off against other considerations beyond the model scope.

*Note that the volcano is in fact a polyhedron with an extremely high number of dimensions.

Model

Single node with cross-border exchange



Scenario data from II3050v2 European Integration for 2050

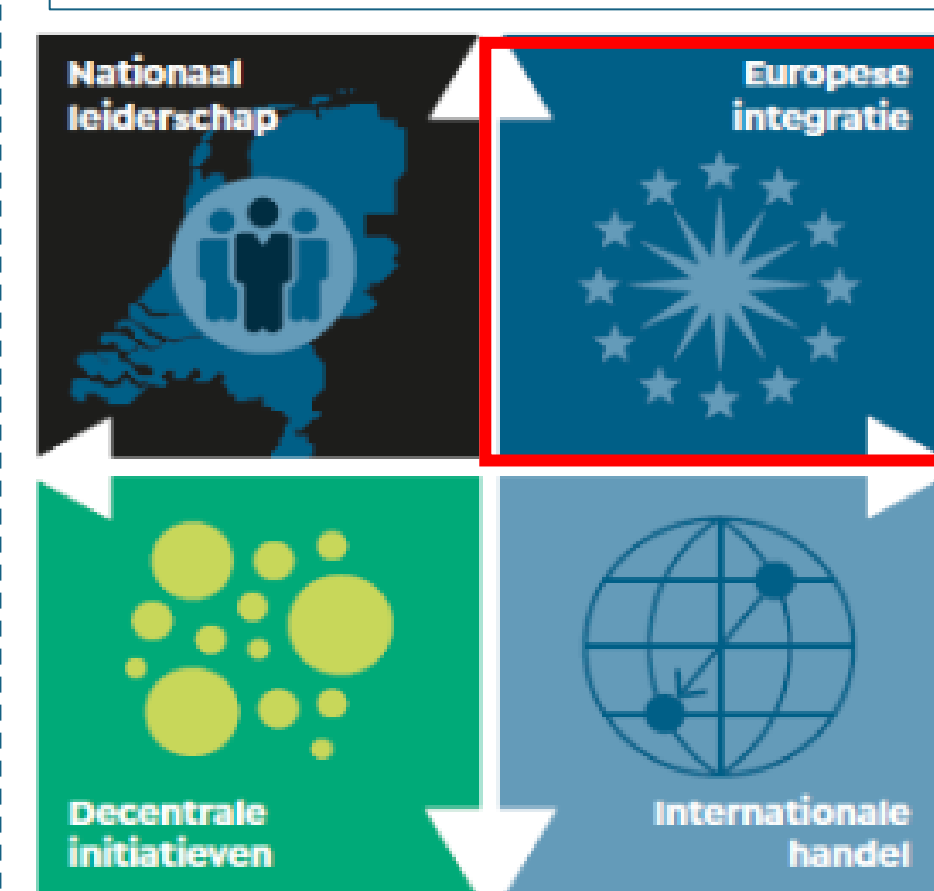

Cross-sectoral implementation at hourly resolution

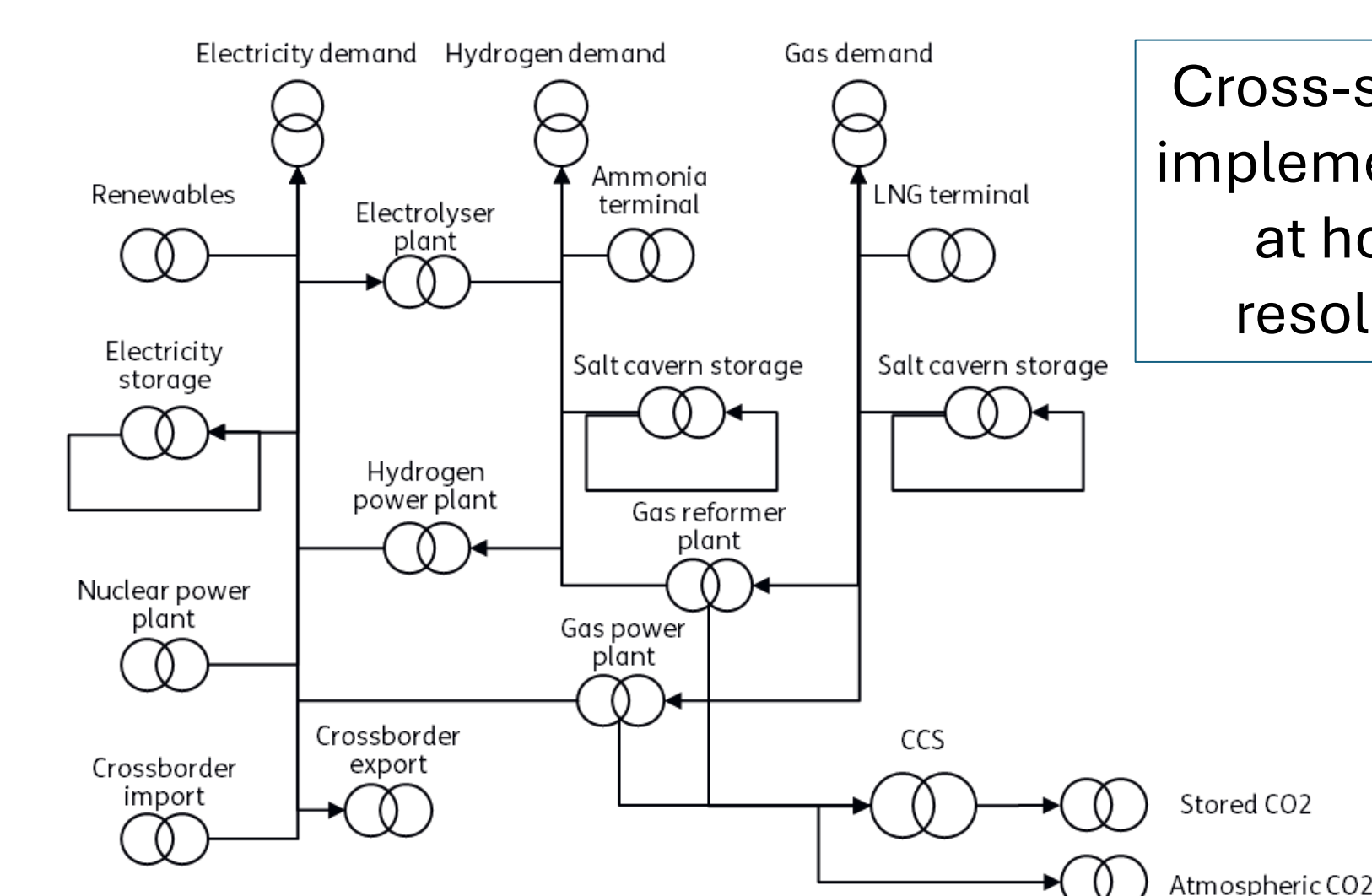

Results

Case	Cost per annum	Renewables	Nuclear
Optimal	42 bn. €	75 GW	0 GW
Near optimal	+5%	45 – 85 GW	0 – 2 GW
Sub optimal	+10%	~40 GW	1 – 5 GW
Still acceptable?	+25%	25 – 150 GW	0 – 19 GW

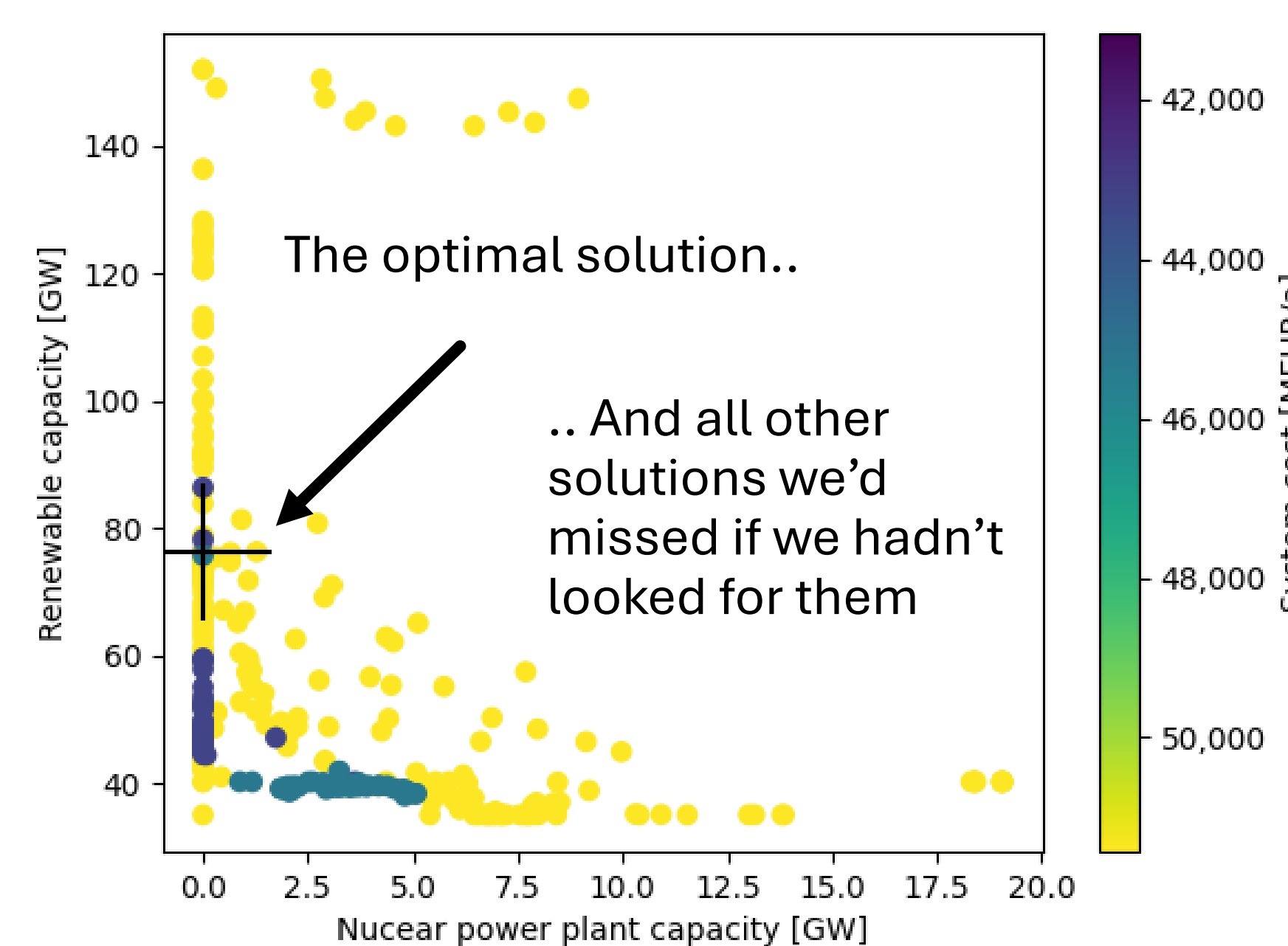

~600 different combinations of energy technology deployment that results in a low-cost, reliable and climate neutral system

Deep dive

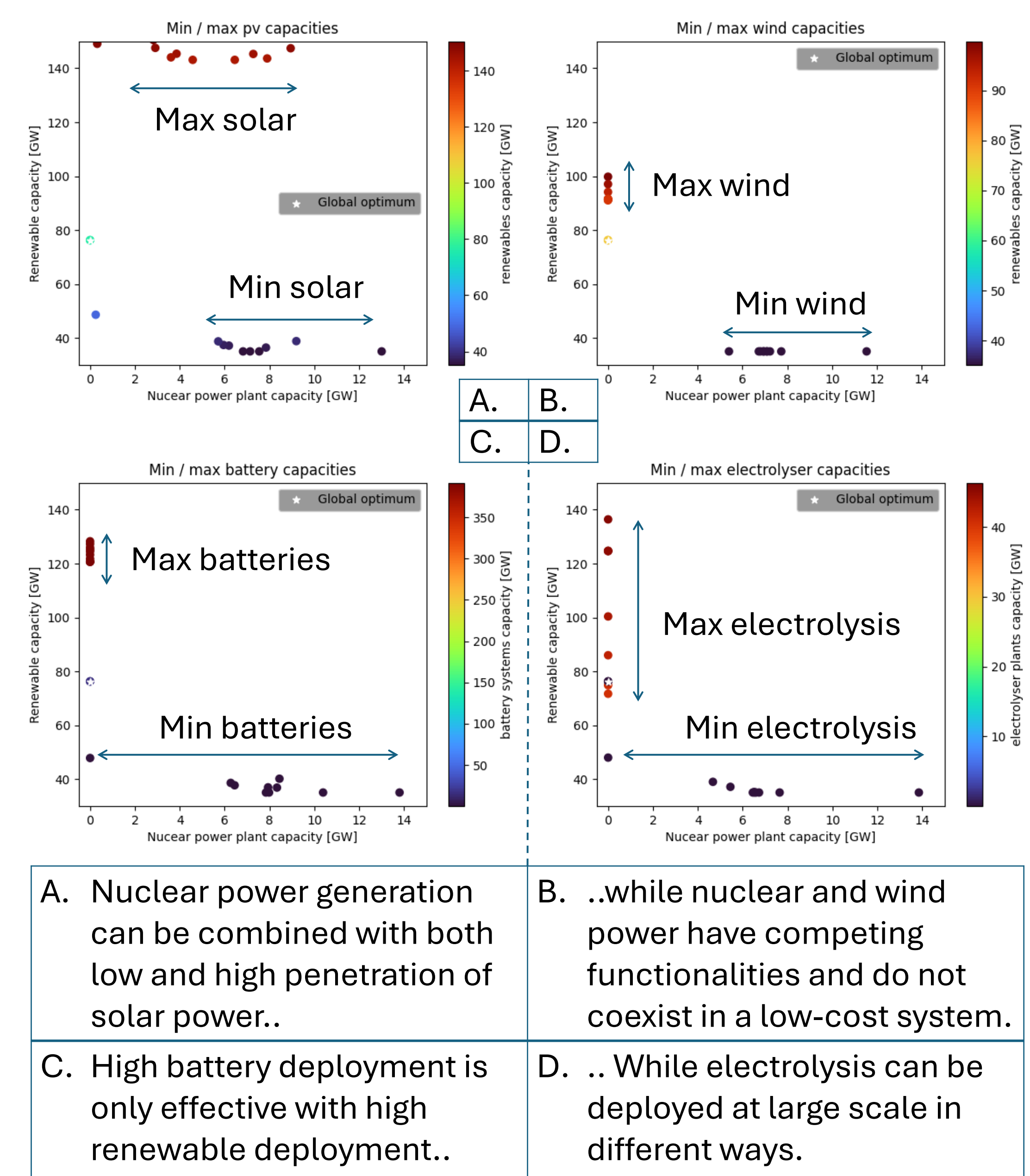

- The **basic principle** is that model **uncertainty** is reduced by calculating a **range of solutions**.
- Uncertainty** is **reduced** as unknown factors that cannot be captured by the model can be **handled elsewhere**.
- We applied the approach to decision making support, but the basic principle **holds** for any **model uncertainty** in **optimization modelling**, e.g. forecasting or scenario analysis.

Next steps

Modelling to generate alternatives (MGA) could also work for other models

From single node to provincial model to study infrastructural constraints

Implementing high resolution grid modeling to find decentralized system designs

